

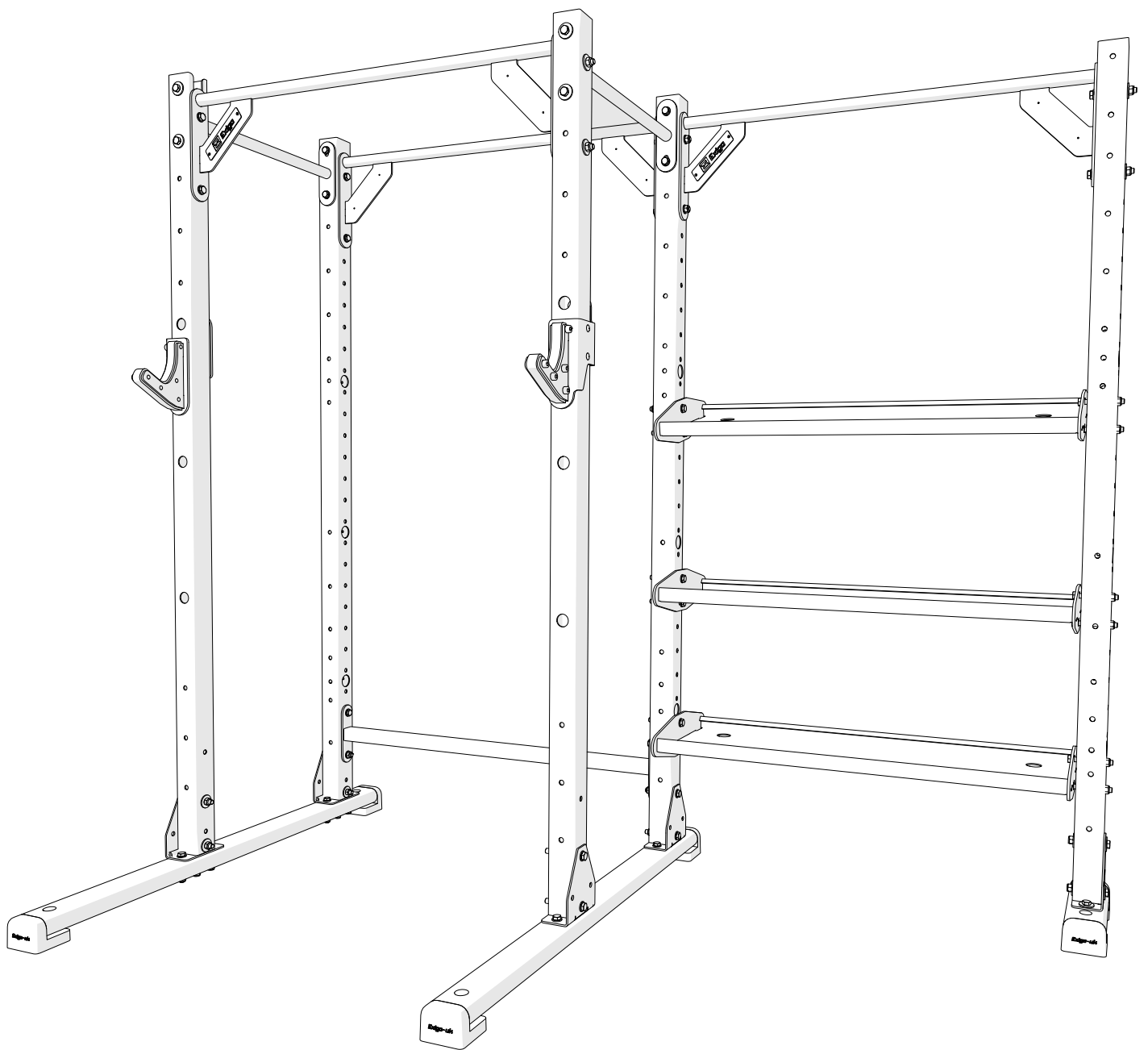



# XF-1323 - HALF RACK ST

## INSTRUCTION MANUAL

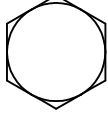
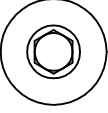
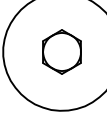
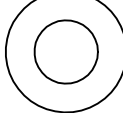
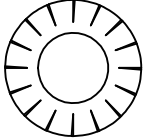
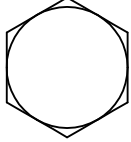
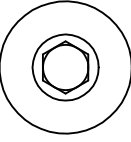
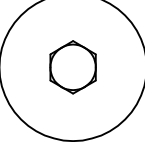
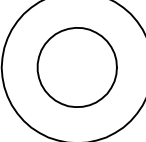
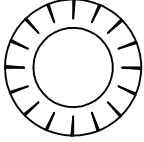
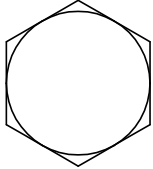
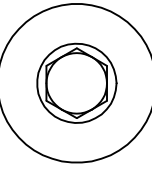
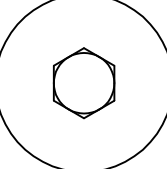
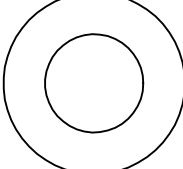
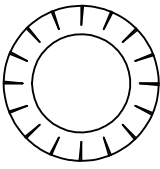
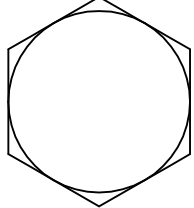
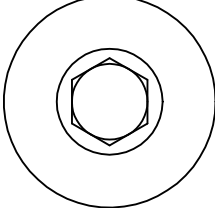
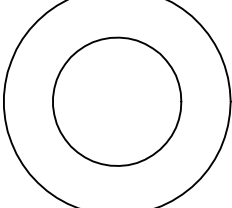
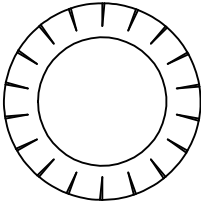

# PLACE THE BOLT HEAD OR WASHER OVER THE SIZING CHART BELOW

	Hex Bolt	Buttonhead	Countersunk	Washer	Fan Disc Washer
M6					
M8					
M10					
M12					
M16					

## MEASURE BOLT FROM THIS LINE AS SHOWN

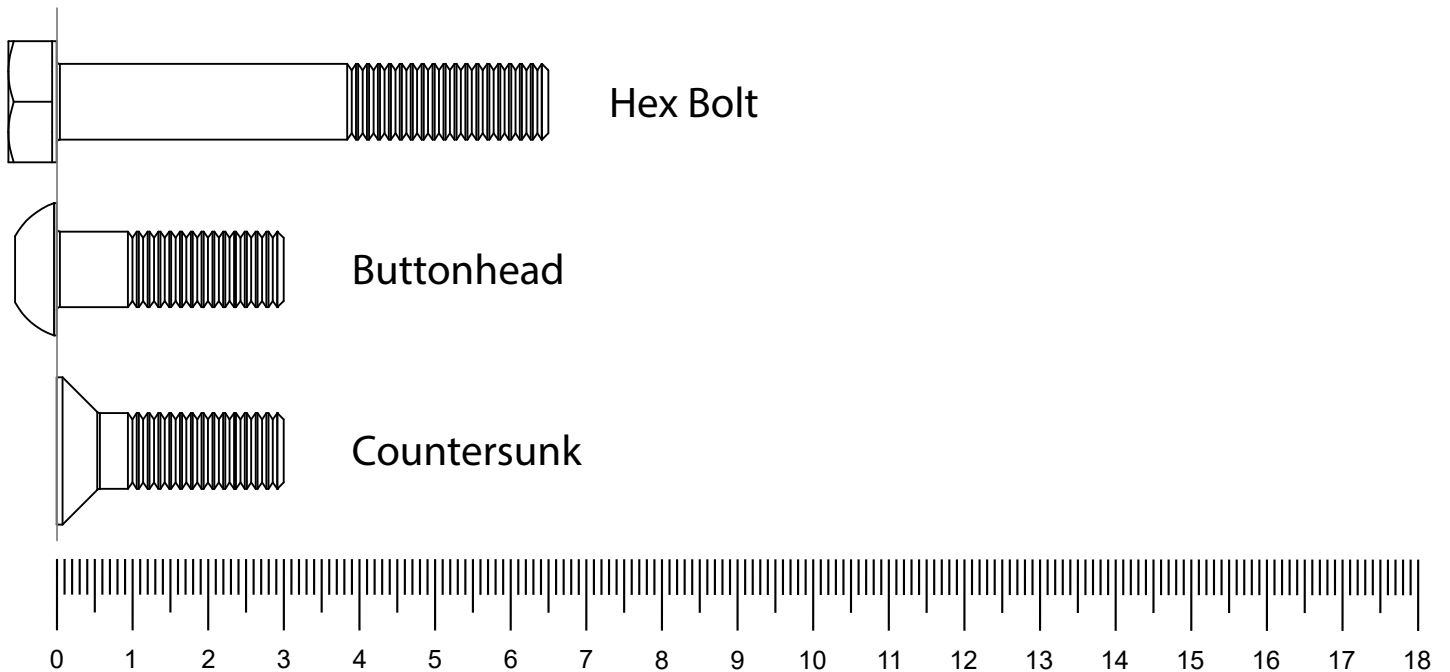

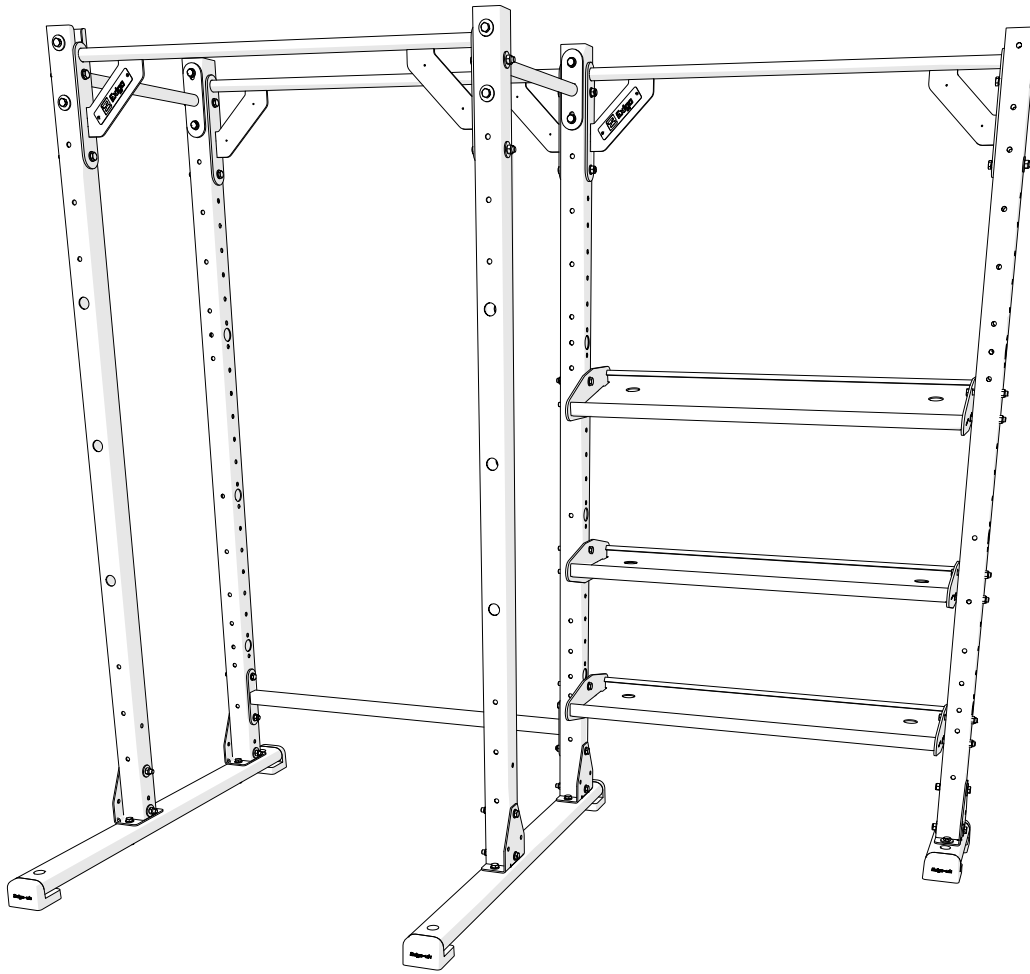

Number	Name	Description	Qty
1	100071	Plastic Foot Cap	6
2	100084	25.4 Dia Plastic Plug Cap	6
3	100181	M12 NYLOC DIN STD Z/P PER 100 T-Type	56
4	100183	M12 WASHER Z/P PER 100	56
5	100184	M12x100 HEX BOLT DIN STD Z/P PER 100	40
6	100205	M12x75 HEX BOLT DIN STD Z/P PER 100	14
7	100207	M12x90 HEX BOLT DIN STD Z/P PER 100	2
8	100263	No8 x 1 1/2 POZI PAN TEK SCREW PER 100	6
9	100500	M12 Form G Washer Ø36 OD	56

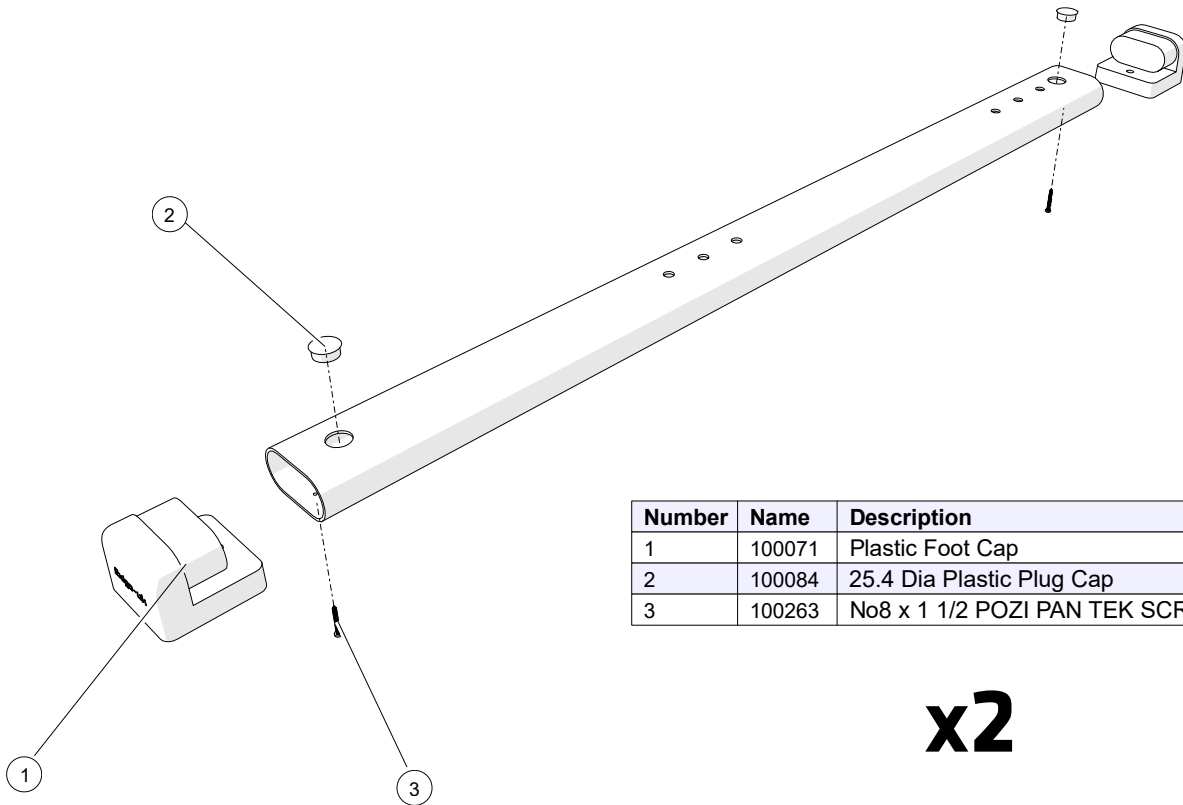

Number	Name	Description	Qty
1	100071	Plastic Foot Cap	2
2	100084	25.4 Dia Plastic Plug Cap	2
3	100263	No8 x 1 1/2 POZI PAN TEK SCREW PER 100	2

**x2**

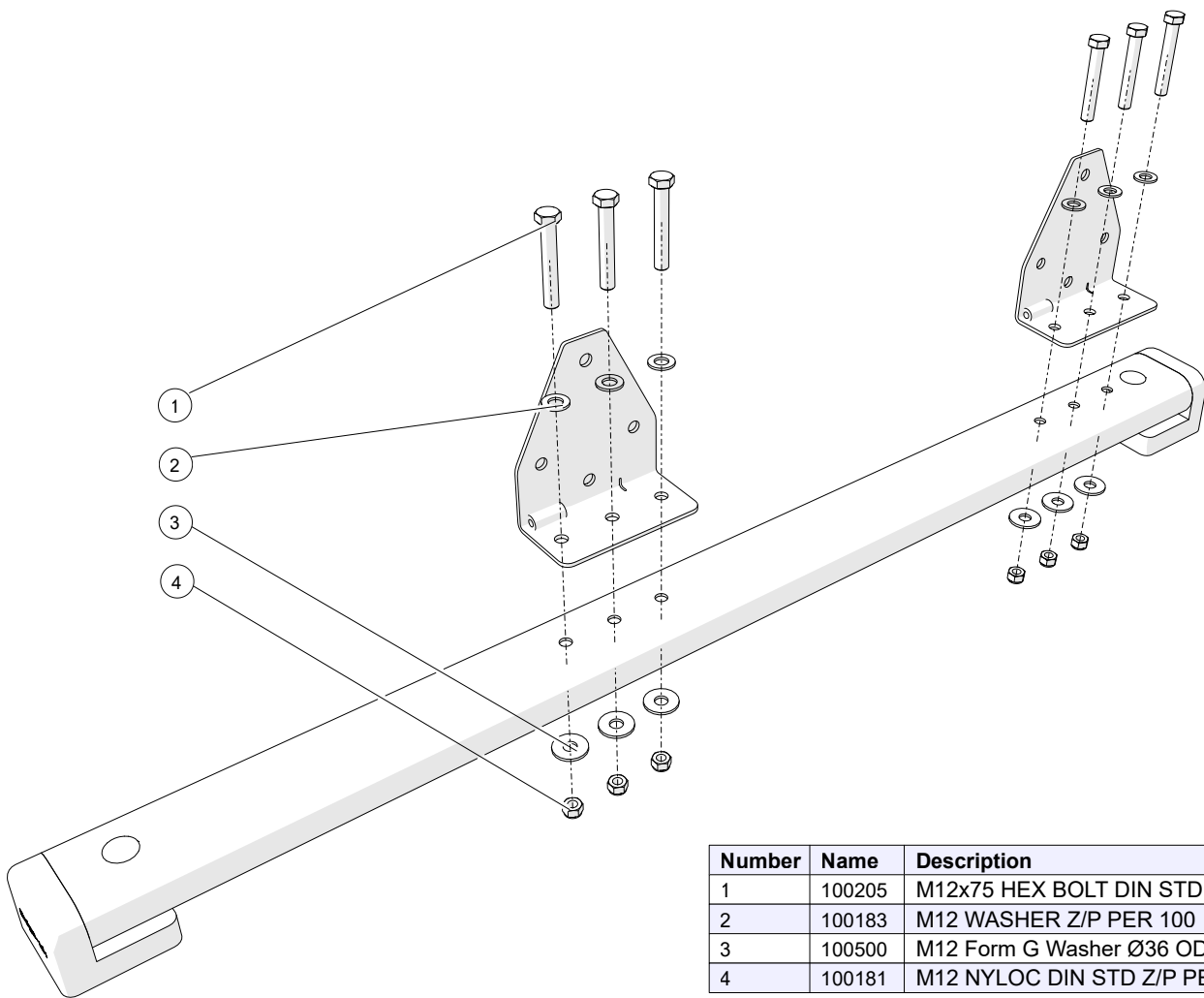

Number	Name	Description	Qty
1	100205	M12x75 HEX BOLT DIN STD Z/P PER 100	6
2	100183	M12 WASHER Z/P PER 100	6
3	100500	M12 Form G Washer Ø36 OD	6
4	100181	M12 NYLOC DIN STD Z/P PER 100 T-Type	6

**x2**

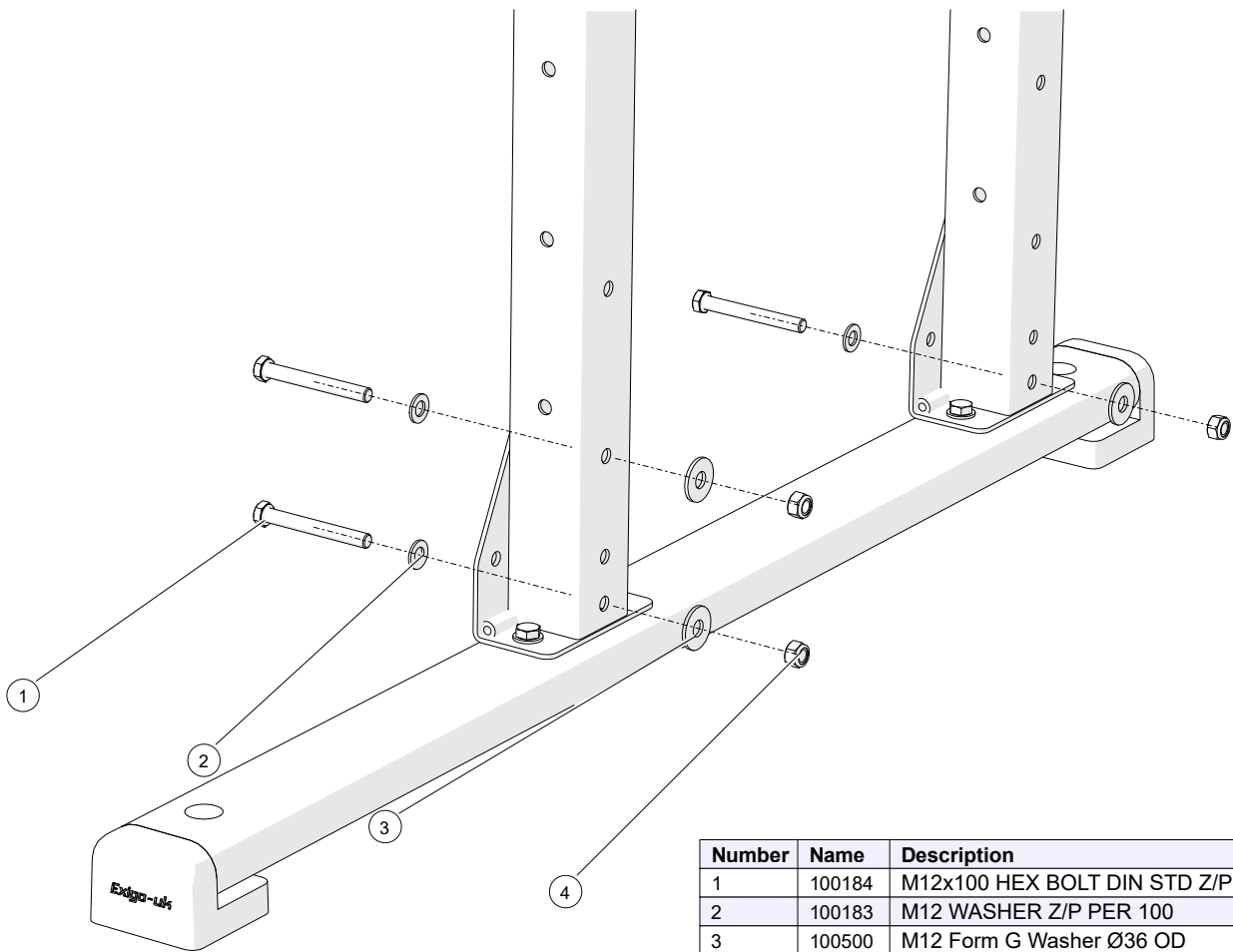
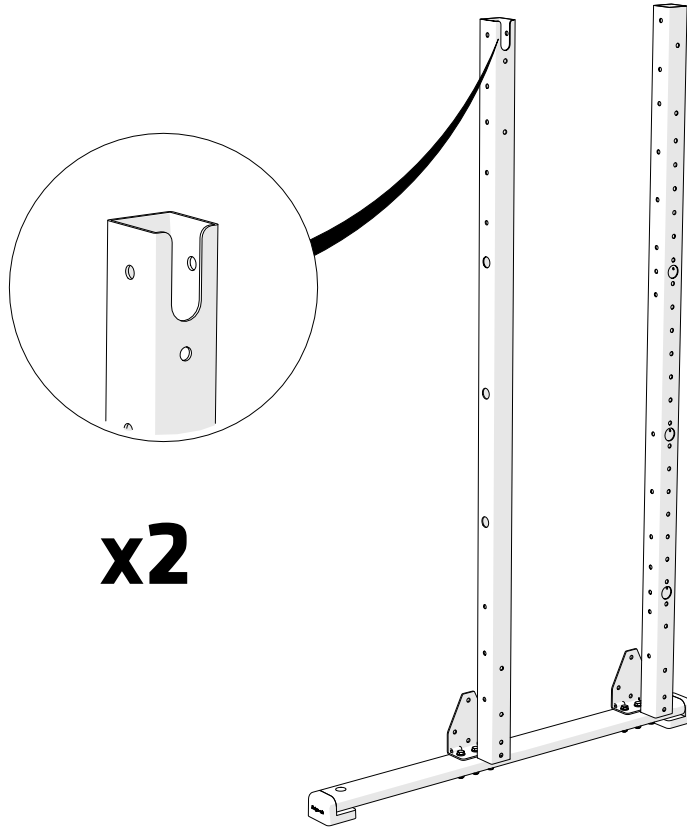

Number	Name	Description	Qty
1	100184	M12x100 HEX BOLT DIN STD Z/P PER 100	3
2	100183	M12 WASHER Z/P PER 100	3
3	100500	M12 Form G Washer Ø36 OD	3
4	100181	M12 NYLOC DIN STD Z/P PER 100 T-Type	3

**x2**

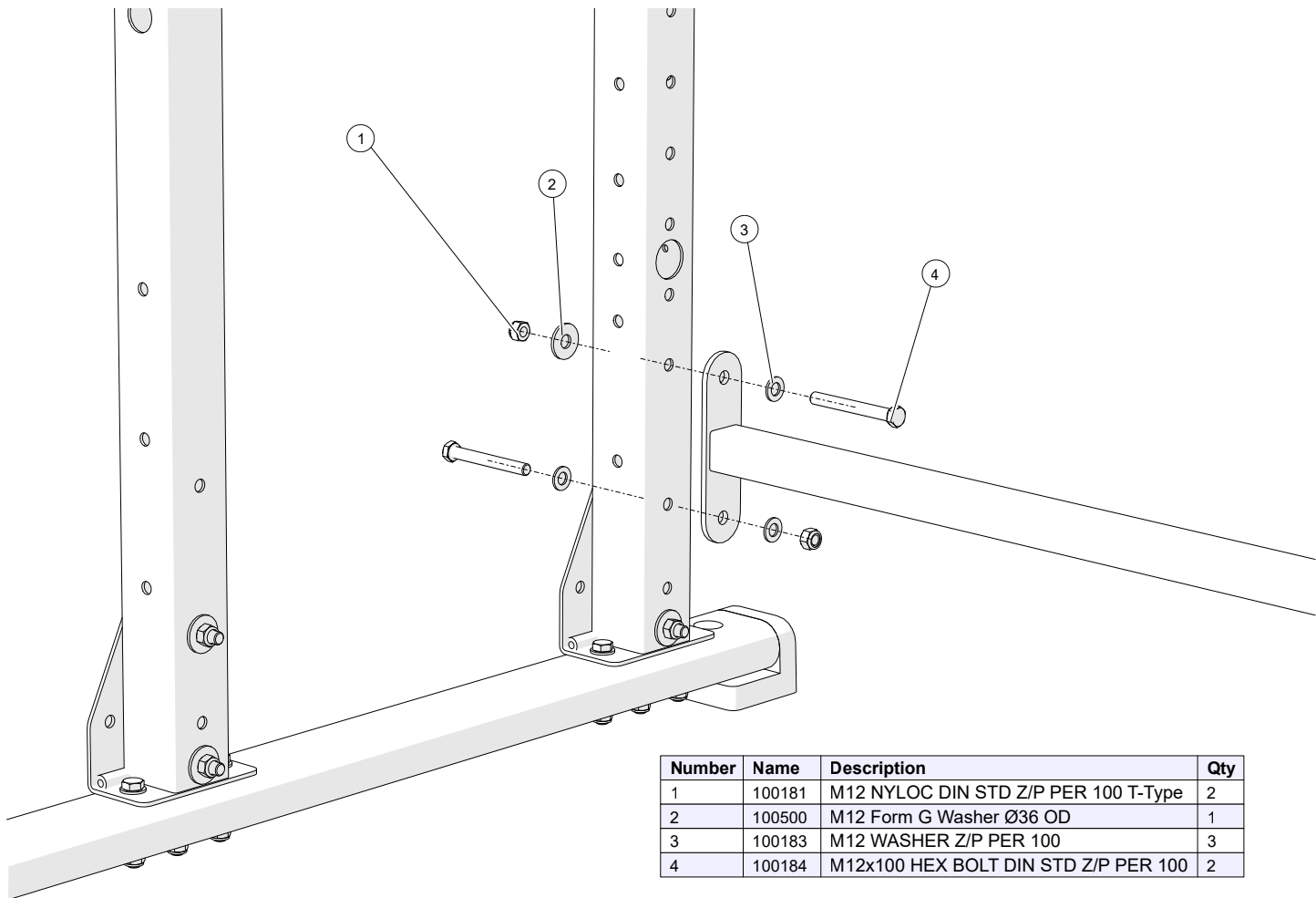

Number	Name	Description	Qty
1	100181	M12 NYLOC DIN STD Z/P PER 100 T-Type	2
2	100500	M12 Form G Washer Ø36 OD	1
3	100183	M12 WASHER Z/P PER 100	3
4	100184	M12x100 HEX BOLT DIN STD Z/P PER 100	2

**x2**

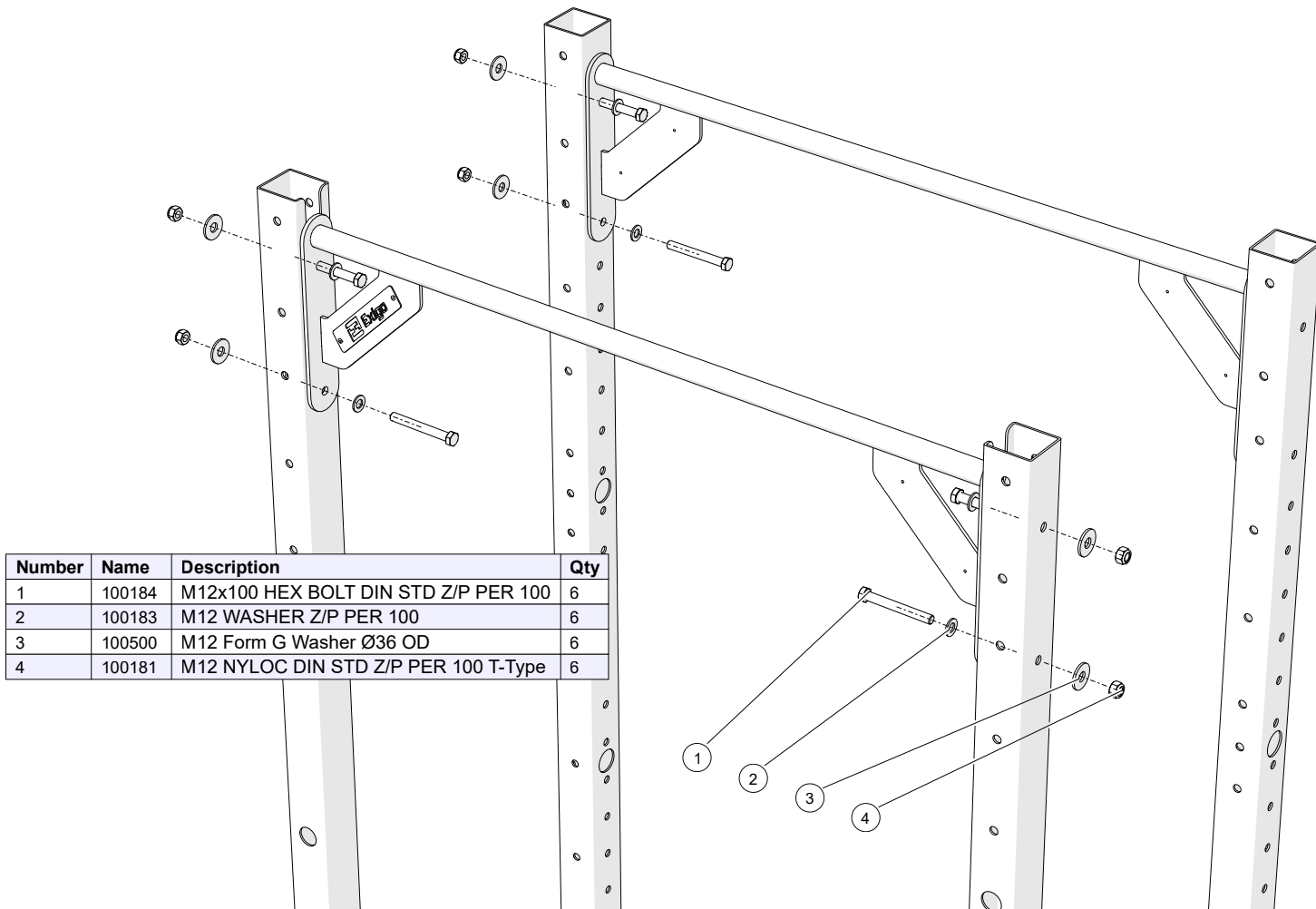

Number	Name	Description	Qty
1	100184	M12x100 HEX BOLT DIN STD Z/P PER 100	6
2	100183	M12 WASHER Z/P PER 100	6
3	100500	M12 Form G Washer Ø36 OD	6
4	100181	M12 NYLOC DIN STD Z/P PER 100 T-Type	6

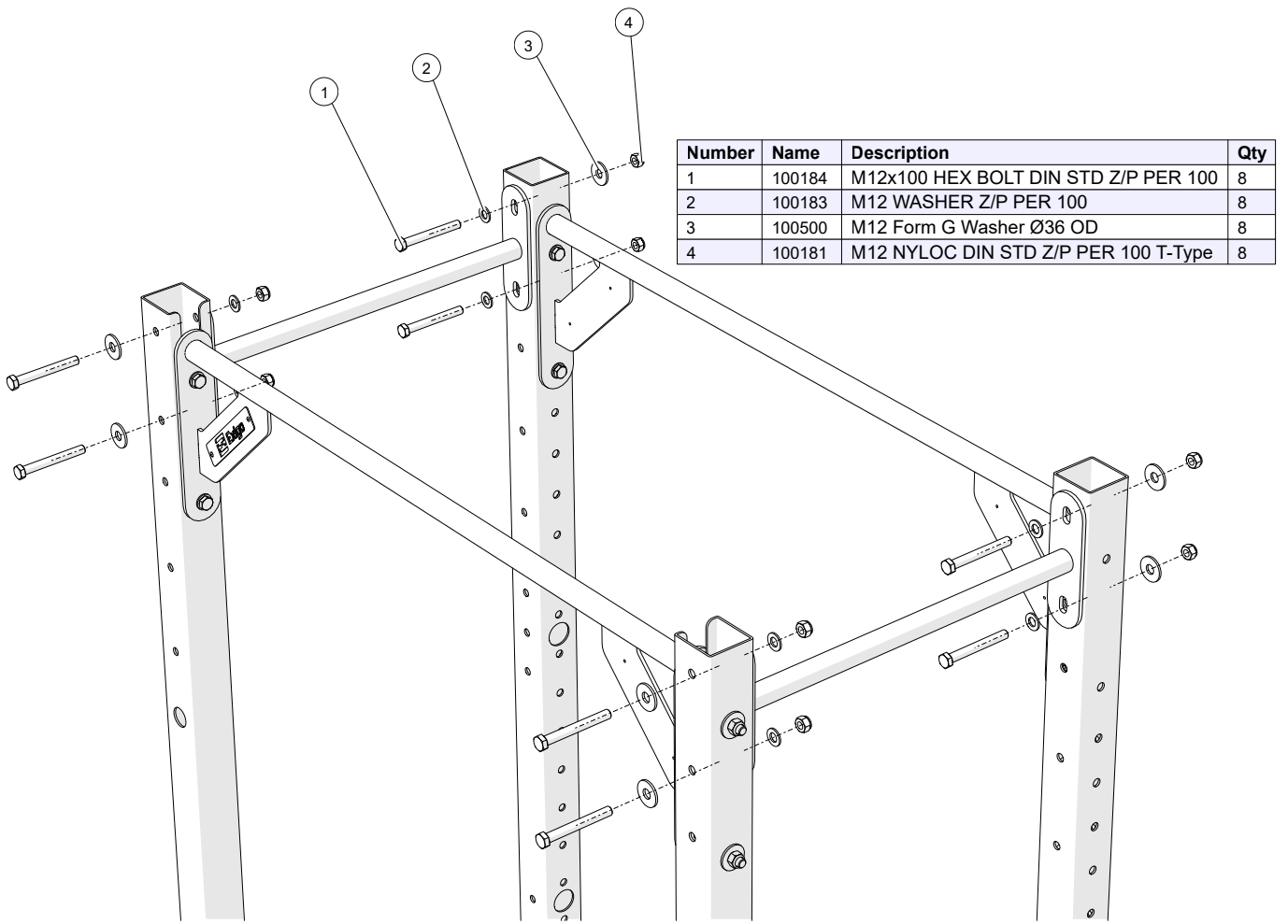

Number	Name	Description	Qty
1	100071	Plastic Foot Cap	2
2	100263	No8 x 1 1/2 POZI PAN TEK SCREW PER 100	2
3	100084	25.4 Dia Plastic Plug Cap	2

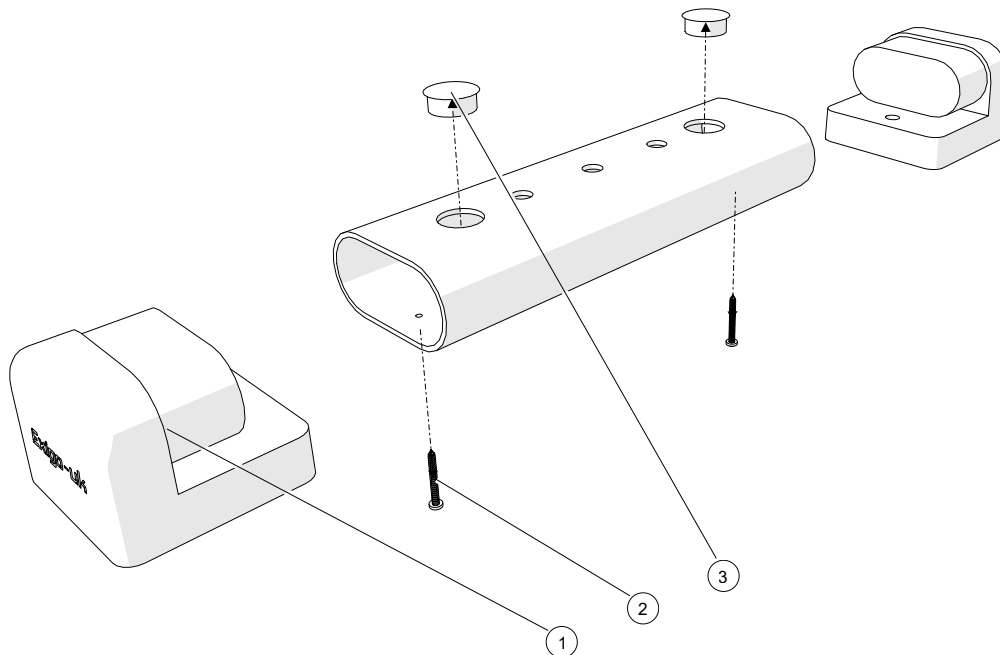

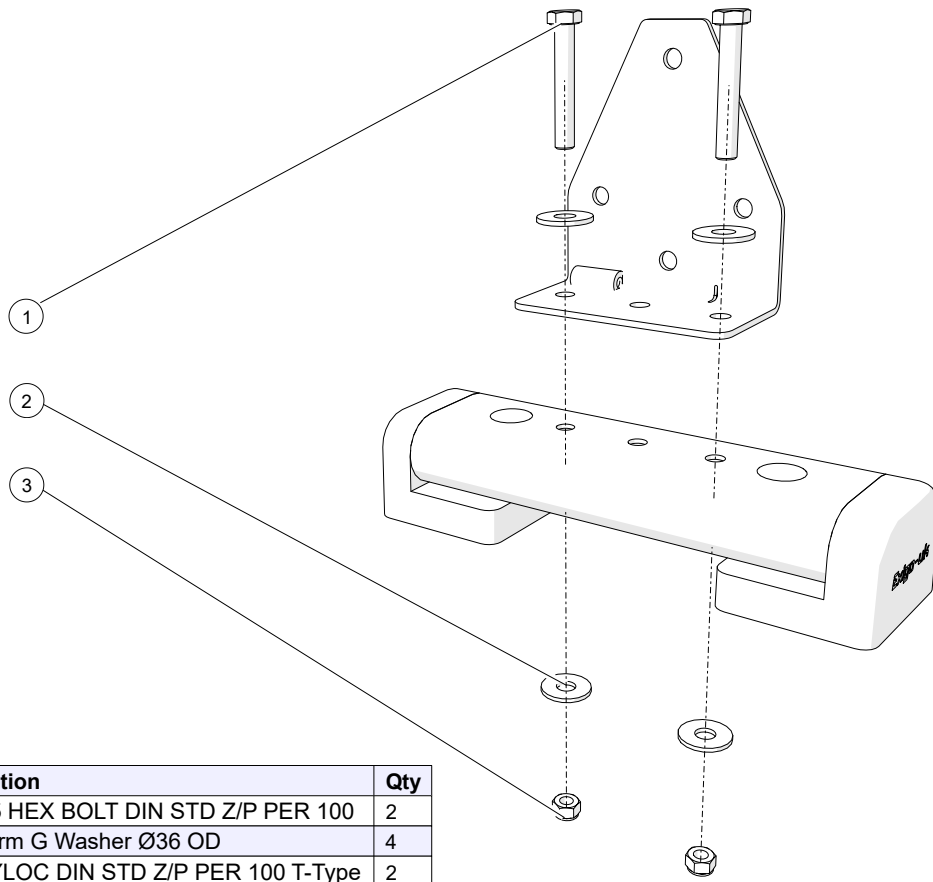

Number	Name	Description	Qty
1	100205	M12x75 HEX BOLT DIN STD Z/P PER 100	2
2	100500	M12 Form G Washer Ø36 OD	4
3	100181	M12 NYLOC DIN STD Z/P PER 100 T-Type	2

Number	Name	Description	Qty
1	100181	M12 NYLOC DIN STD Z/P PER 100 T-Type	2
2	100500	M12 Form G Washer Ø36 OD	4
3	100207	M12x90 HEX BOLT DIN STD Z/P PER 100	2

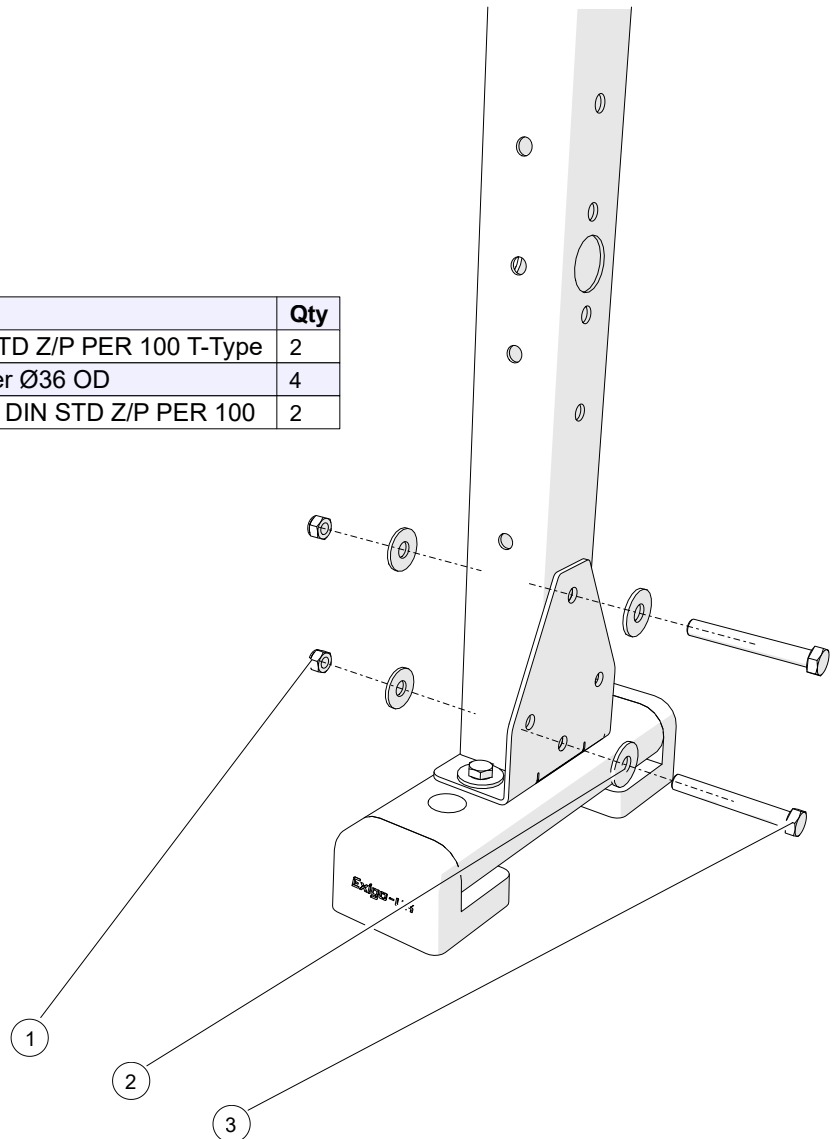



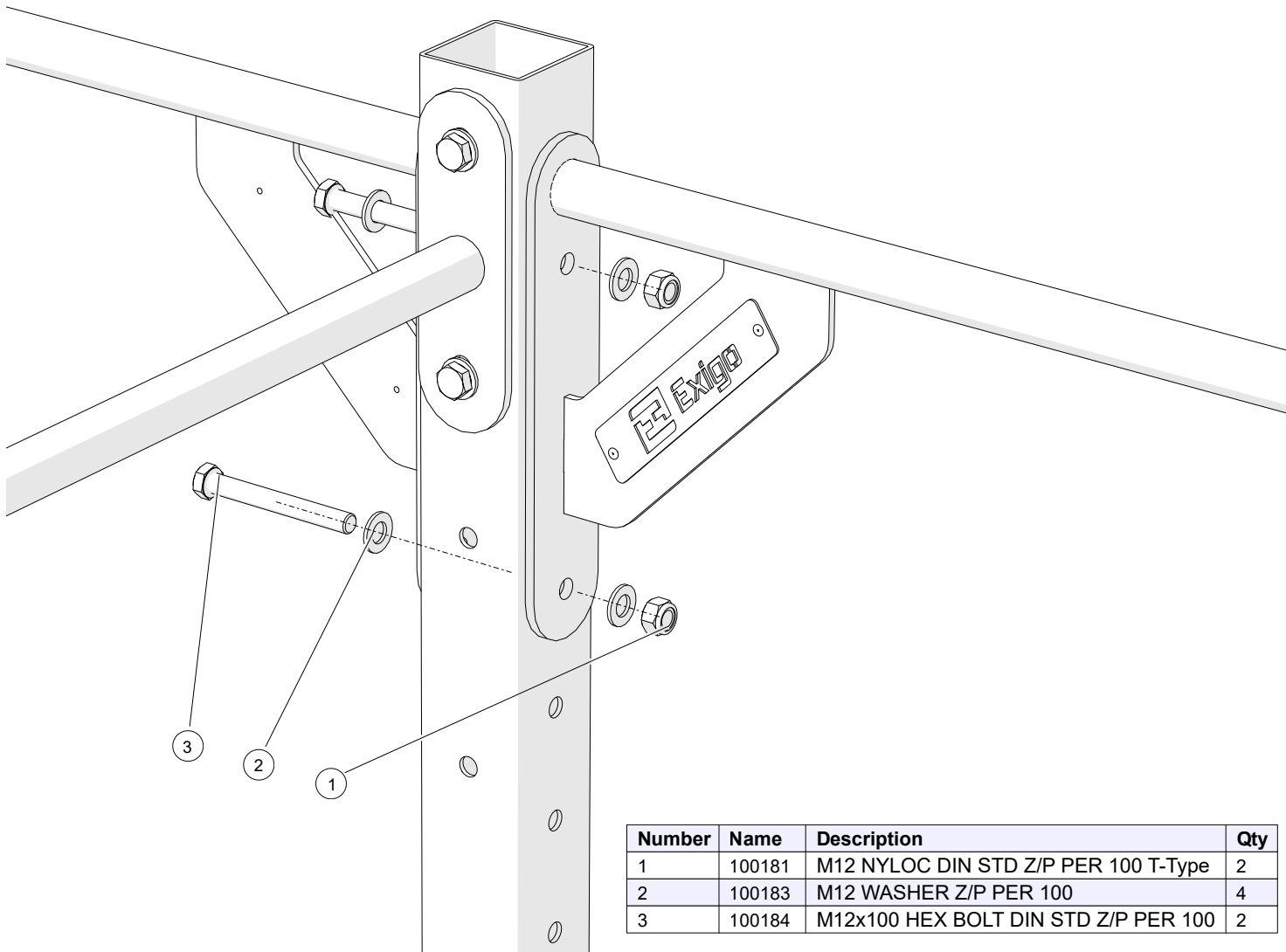
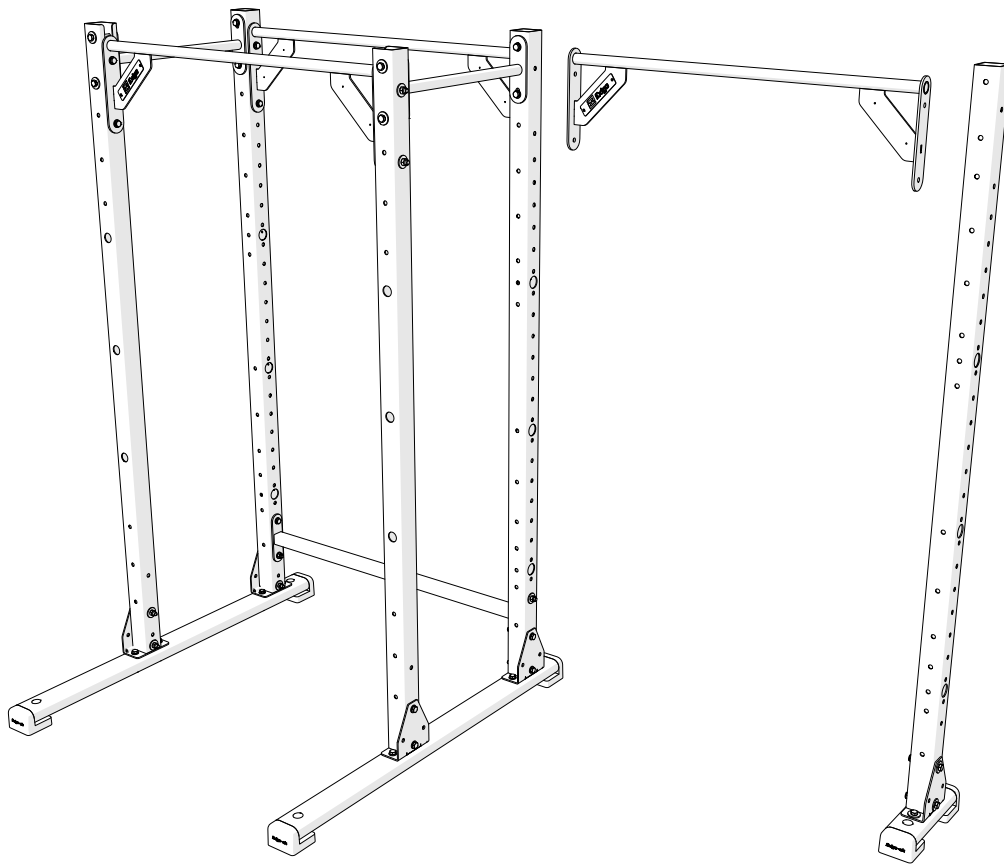

Number	Name	Description	Qty
1	100181	M12 NYLOC DIN STD Z/P PER 100 T-Type	2
2	100183	M12 WASHER Z/P PER 100	4
3	100184	M12x100 HEX BOLT DIN STD Z/P PER 100	2

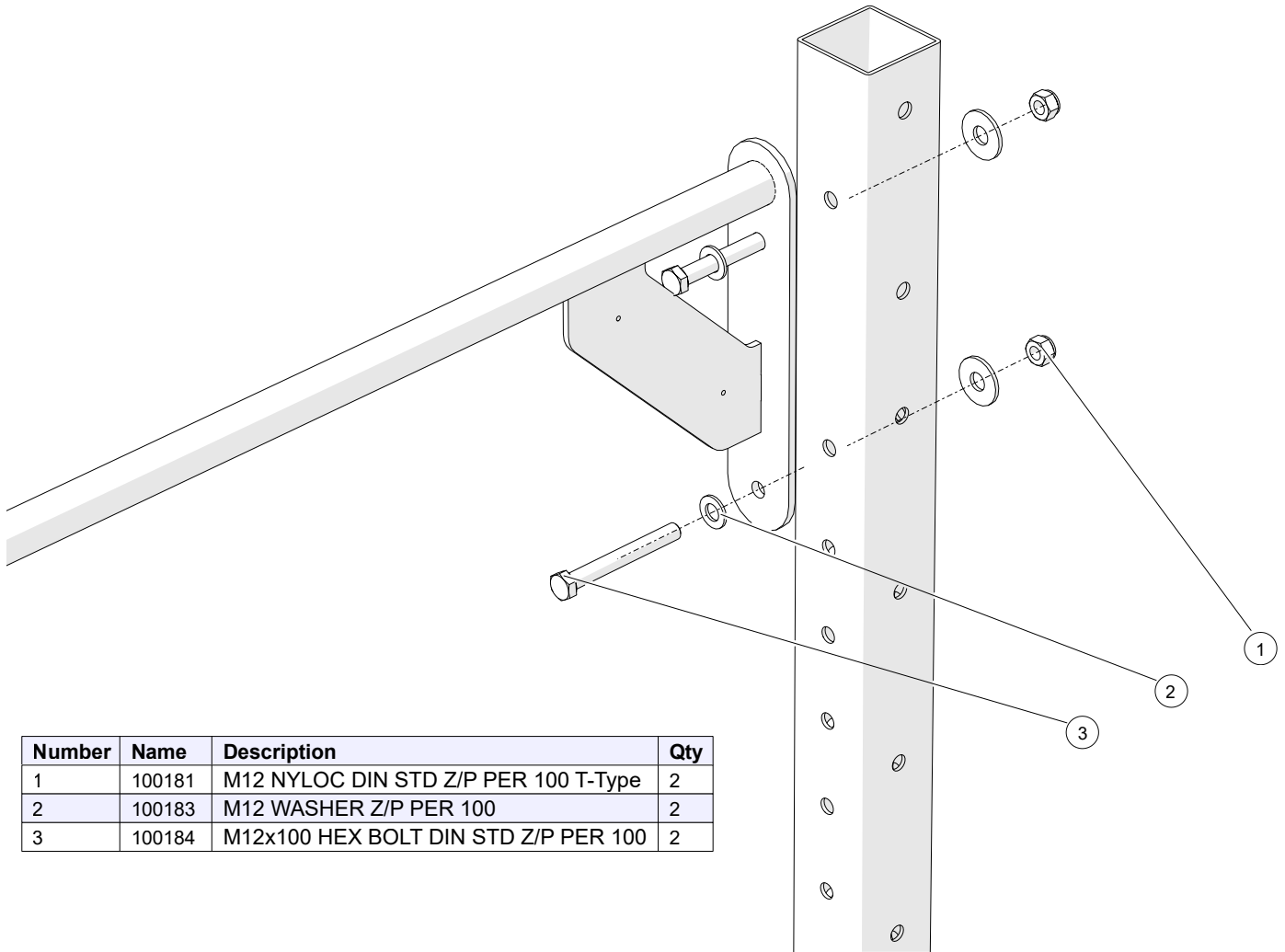
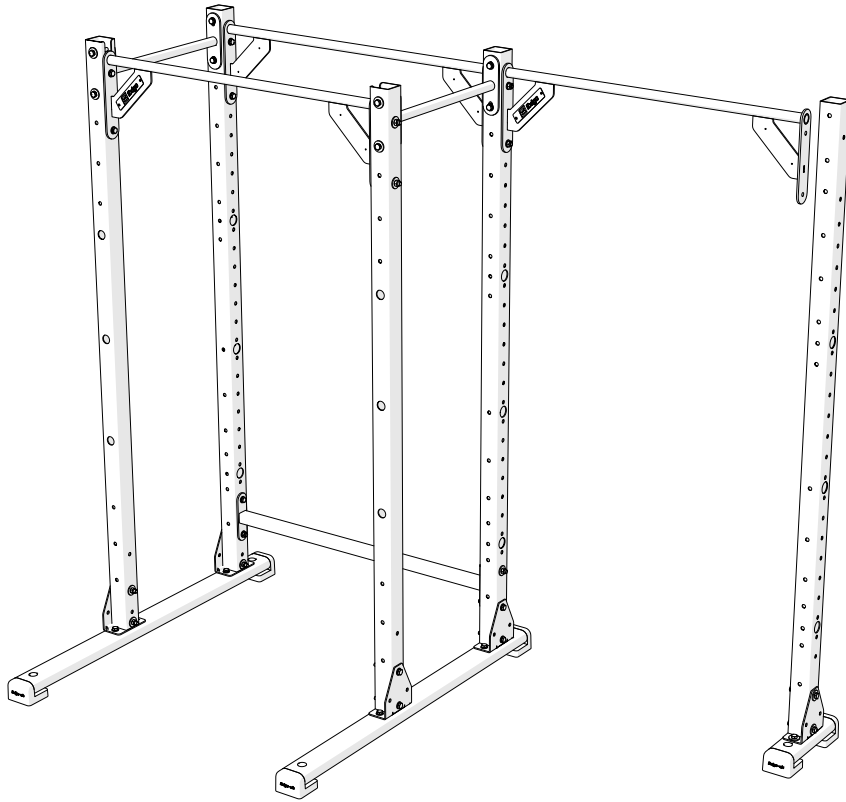

Number	Name	Description	Qty
1	100181	M12 NYLOC DIN STD Z/P PER 100 T-Type	2
2	100183	M12 WASHER Z/P PER 100	2
3	100184	M12x100 HEX BOLT DIN STD Z/P PER 100	2

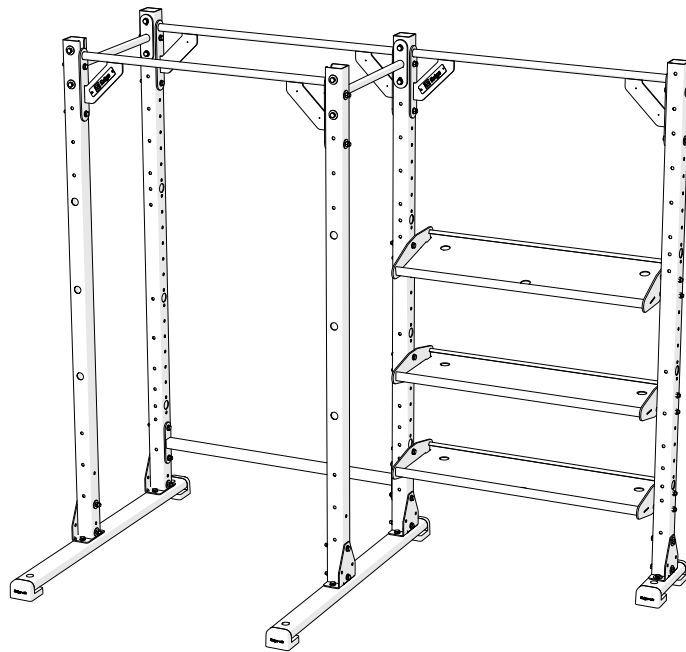

## Flat tray

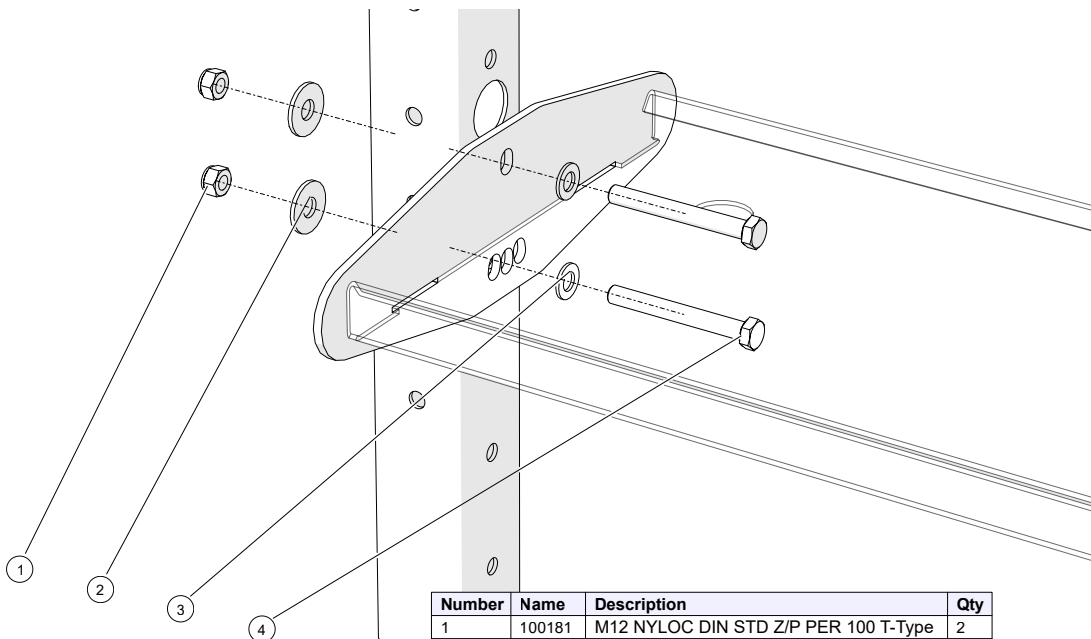

Number	Name	Description	Qty
1	100181	M12 NYLOC DIN STD Z/P PER 100 T-Type	2
2	100500	M12 Form G Washer Ø36 OD	2
3	100183	M12 WASHER Z/P PER 100	2
4	100184	M12x100 HEX BOLT DIN STD Z/P PER 100	2

## 12° Angled tray

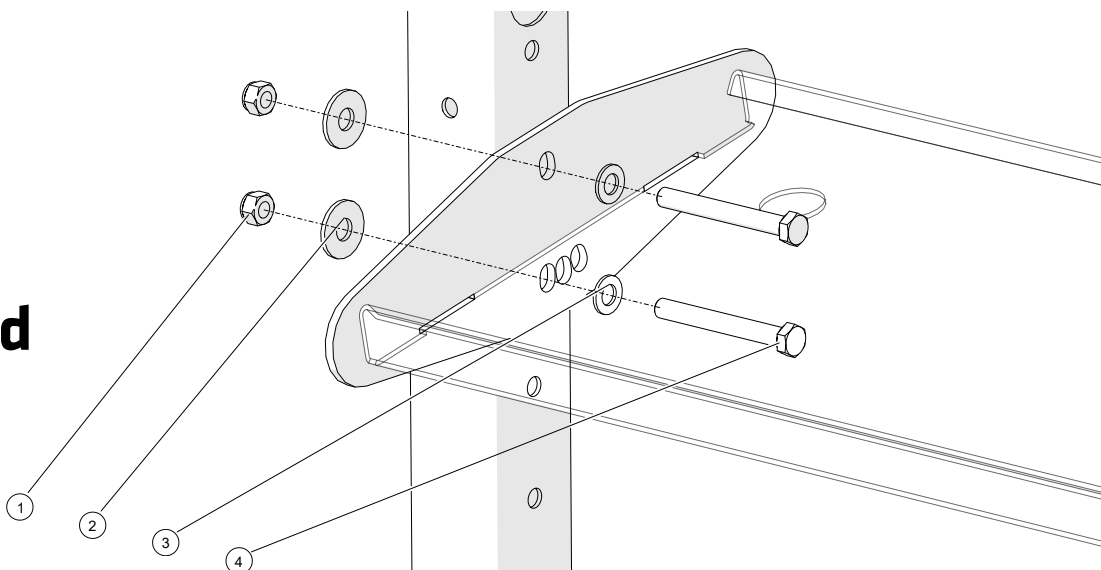

Number	Name	Description	Qty
1	100181	M12 NYLOC DIN STD Z/P PER 100 T-Type	2
2	100500	M12 Form G Washer Ø36 OD	2
3	100183	M12 WASHER Z/P PER 100	2
4	100184	M12x100 HEX BOLT DIN STD Z/P PER 100	2